

SPECIFICATION SHEET

NWHE-EM**6" Series — HEXALED 2.0****New Construction Housing with Emergency Lighting**

Project _____

Notes _____

Fixture type _____

Date _____

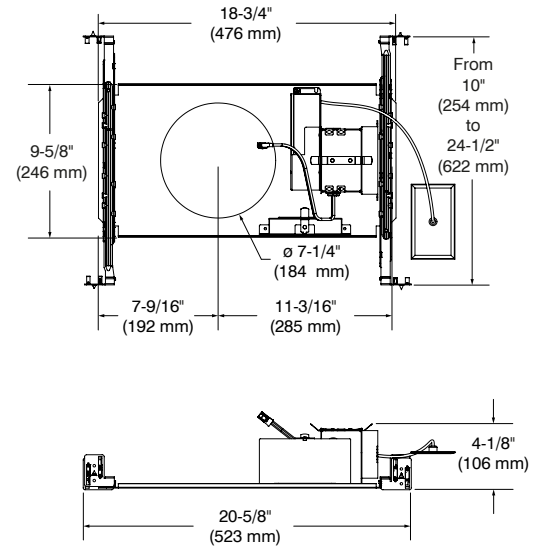
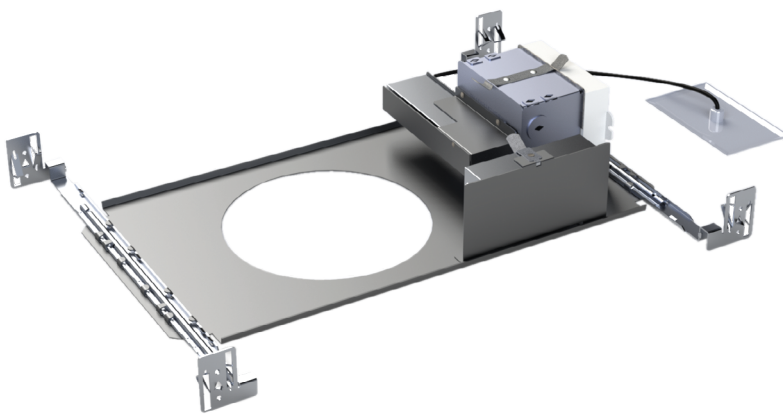
**SPECIFICATIONS**

HOUSING DETAILS	Galvanized steel housing Junction box can support up to 10 - 14 gauge wires or 8 - 12 gauge wires (90° wires) Below-ceiling accessible
EMERGENCY LIGHTING	Runtime: 120 minutes minimum Maximum height installation: 50' Test button with 24" wire and decorative plate (included) Battery Lifespan: 5 years 1,325 lumens in emergency mode
MOUNTING AND SUPPORT	Ceiling Cutout: \varnothing 7-1/4" (184 mm) Requires a 6-3/4" (172 mm) clearance beyond the ceiling level. Insulation material must be kept at least 3" (76 mm) away from the fixture. Mounting bars extend from 10" (254 mm) to 24-1/2" (622 mm) to fit in most ceiling structures. Can fit in ceiling up to 1-1/2" (38 mm) thick. Perfect fit into ceiling. No light leak.
VOLTAGE	120V - 277V
PILOTE (OPTIONS)	PERFORMANCE 20W, 28W, 36W and 50W 20W (2,390 lumens) 36W (4,190 lumens) 28W (3,280 lumens) 50W (5,340 lumens) <u>1 type of dimming offered:</u> • 0-10V (Sinking Control)

Due to constant evolution of LED lamps and associate dimmers we must test them regularly.

We invite you to consult frequently our Web site to find our dimmer compatibility list: www.contrastlighting.com

CONTRASTE

NWHE-EM

6" Series — HEXALED 2.0

New Construction Housing with Emergency Lighting



SPECIFICATIONS (CONT'D)

COMPATIBLE TRIMS	HEF-xx (fixed) HED-xx (adjustable)
CERTIFICATION	<ul style="list-style-type: none"> cULus E343977 for damp locations Energy Star certified
WARRANTY	5-year limited on LED driver

CODIFICATION EXAMPLE

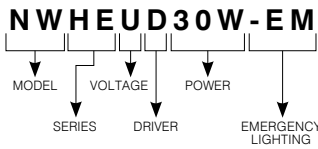

ORDERING CODES

MODEL	SERIES	VOLTAGE	DRIVER	POWERS	EMERGENCY LIGHTING
NW	HE	U	D		-EM
NW New Construction Housing	HE HexaLED	U Universal (120V/277V)	D 0-10V (Sinking Control)	20W 2,390 lumens 28W 3,280 lumens 36W 4,190 lumens 50W 5,340 lumens	-EM Emergency Lighting 1,325 lumens